

Back Pressure Regulators

	Description	Overpressure max. bar	Adjustment range bar	Connection thread	Device	Page
standard	aluminium	30	0.2 ... 1.5 / 15	G $\frac{1}{8}$ - G2	DBC	8.02
	brass	65	0.2 ... 1.5 / 50	G $\frac{1}{8}$ - G2	DBM	8.04
	+130 °C	65	0.2 ... 1.5 / 50	G $\frac{1}{8}$ - G $\frac{1}{2}$	DBM-X54	8.05
precise	high-precision	35	0.01 ... 0.14 / 28	G $\frac{1}{4}$ - G $\frac{1}{2}$	10BP	8.06
	free of non-ferrous metal	35	0.01 ... 0.14 / 28	G $\frac{1}{4}$ - G $\frac{1}{2}$	10BP-X63	8.06
	aluminium	17	0.01 ... 0.14 / 10	G $\frac{1}{4}$ - $\frac{1}{2}$ "NPT	DB240	8.07
	aluminium	10	0.001 ... 0.14 / 7	G $\frac{1}{4}$ and G $\frac{3}{8}$	DB300	8.09
	aluminium	17	0.03 ... 0.7 / 10	G $\frac{3}{8}$ - G $\frac{3}{4}$	DB400	8.10
low pressure	precise	10	0.002 ... 0.035 / 0.8	G $\frac{1}{4}$ - G $\frac{1}{2}$	DB110	8.08
	precise	6	0.005 ... 0.045 / 3	G $\frac{1}{2}$ - G2	DBC	8.11
pilot-operated	precise	17	0 ... 10	G $\frac{1}{4}$ - G $\frac{1}{2}$	DB208	8.12
	precise	17	0 ... 10	G $\frac{3}{8}$ - G $\frac{3}{4}$	DB450	8.13
miniature	screw-in, knurled screw	21	1.7 ... 2.4 / 14	G $\frac{1}{4}$ a	59	8.14
	screw-in, plastic knob	21	0 ... 3.5 / 7	G $\frac{1}{4}$ a	130	8.14
	tapped exhaust	21	0 ... 1.0 / 7	G $\frac{1}{4}$	134	8.14
stainless steel	for many gases, FDA also	65	0.1 ... 1.5 / 50	G $\frac{1}{8}$ - G2	D3000	15.24
	+130 °C	65	0.1 ... 1.5 / 50	G $\frac{1}{4}$ - G2	D3000-X54	15.27
	low pressure	6	0.005 ... 0.045 / 3	G $\frac{1}{2}$ - G2	D3100	15.28



8

Back Pressure Regulators

Description	Back pressure regulators protect pneumatic devices against overpressure. If the pressure exceeds the setpoint, the pressure valve exhausts to the atmosphere until the pressure level is below the setpoint. It is advisable to select the pressure range as near as possible to the maximum setpoint.		
Media	compressed air or non-corrosive gases		
Overpressure	max. 30 bar		
Adjustment	by plastic knob with snap-lock for DBC-01, by T-handle with locknut for DBC-06 to -16	by handwheel for DBC-02 to -A6	
Gauge port	G $\frac{1}{8}$ at DBC-01, G $\frac{1}{4}$ from DBC-02 on, on both sides of the body, screw plugs supplied		
Mounting position	any		
Temperature range	0 °C to 60 °C / 32 °F to 140 °F, for appropriately conditioned compressed air down to -20 °C / -4 °F		
Material	Body: aluminium Diaphragm: NBR/Buna-N with PTFE coating	O-rings: NBR/Buna-N, optionally FKM or EPDM	Inner valve: brass

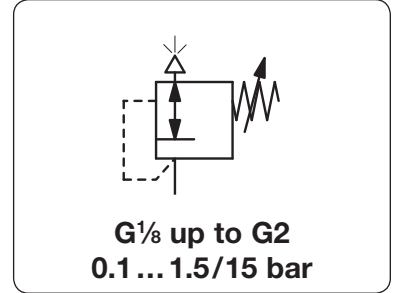

Dimensions			Regul. system	Relief capacity	Over-pressure	Connection thread	Adjustment range	Order number
A	B	C	D: diaphragm P: piston	l/min*1	max. bar	G	bar	

Aluminium back pressure regulator								overpressure max. 30 bar	DBC
40	82	13	D	200	30	G $\frac{1}{8}$	0.2 ... 1.5	DBC-01A	
							0.3 ... 3.0	DBC-01B	
							0.8 ... 8.0	DBC-01D	
							1.5 ... 15	DBC-01E	
40	82	13	D	200	30	G $\frac{1}{4}$	0.2 ... 1.5	DBC-A2A	
							0.3 ... 3.0	DBC-A2B	
							0.8 ... 8.0	DBC-A2D	
							1.5 ... 15	DBC-A2E	
78	167	33	D	400	30	G $\frac{1}{4}$	0.2 ... 1.5	DBC-02A	
							0.3 ... 3.0	DBC-02B	
							0.8 ... 8.0	DBC-02D	
							1.5 ... 15	DBC-02E	
78	167	33	D	500	30	G $\frac{3}{8}$	0.2 ... 1.5	DBC-03A	
							0.3 ... 3.0	DBC-03B	
							0.8 ... 8.0	DBC-03D	
							1.5 ... 15	DBC-03E	
82	178	38	D	2200	30	G $\frac{1}{2}$	0.2 ... 1.5	DBC-04A	
							0.3 ... 3.0	DBC-04B	
							0.8 ... 8.0	DBC-04D	
							1.5 ... 15	DBC-04E	
82	178	38	D	2500	30	G $\frac{3}{4}$	0.2 ... 1.5	DBC-A6A	
							0.3 ... 3.0	DBC-A6B	
							0.8 ... 8.0	DBC-A6D	
							1.5 ... 15	DBC-A6E	

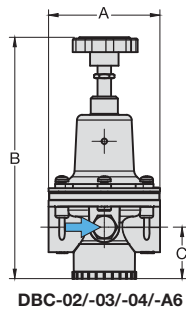
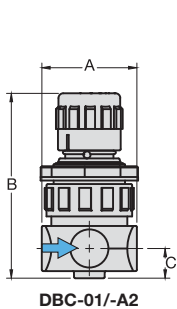
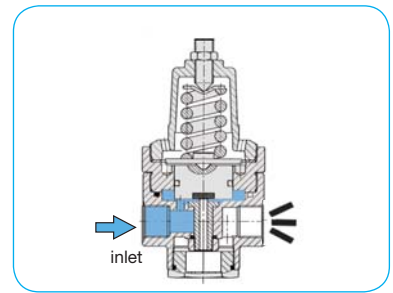
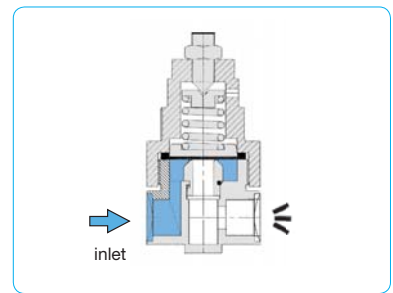

*1 at 7 bar overpressure and open outlet
*2 02 = 0...2.5 bar, 04 = 0...4 bar, 06 = 0...6 bar, 10 = 0...10 bar, 16 = 0...16 bar

Gauges: see chapter for measuring devices

PDF CAD
www.aircom.net

Order example:
DBC-01A

Description	Back pressure regulators protect pneumatic devices against overpressure. If the pressure exceeds the setpoint, the pressure valve exhausts to the atmosphere until the pressure level is below the setpoint. It is advisable to select the pressure range as near as possible to the maximum setpoint.		
Media	compressed air or non-corrosive gases		
Overpressure	max. 30 bar		
Adjustment	by plastic knob with snap-lock for DBC-01, by T-handle with locknut for DBC-06 to -16	by handwheel for DBC-02 to -A6	
Gauge port	G $\frac{1}{8}$ at DBC-01, G $\frac{1}{4}$ from DBC-02 on, on both sides of the body, screw plugs supplied		
Mounting position	any		
Temperature range	0 °C to 60 °C / 32 °F to 140 °F, for appropriately conditioned compressed air down to -20 °C / -4 °F		
Material	Body: aluminium	O-rings: NBR/Buna-N, optionally FKM or EPDM	Inner valve: brass
	Diaphragm: NBR/Buna-N with PTFE coating		

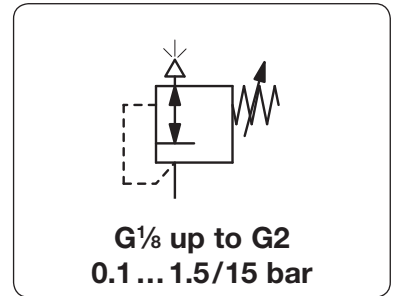

Dimensions			Regul. system	Relief capacity	Over-pressure	Connection thread	Adjustment range	Order number
A	B	C	D: diaphragm P: piston	l/min*1	max. bar	G	bar	

Aluminium back pressure regulator								overpressure max. 30 bar	DBC
126	293	66	D	4000	30	G $\frac{3}{4}$	0.2 ... 1.5	DBC-06A	
							0.3 ... 3.0	DBC-06B	
							0.8 ... 8.0	DBC-06D	
							1.5 ... 15	DBC-06E	
126	293	66	D	4000	30	G1	0.2 ... 1.5	DBC-08A	
							0.3 ... 3.0	DBC-08B	
							0.8 ... 8.0	DBC-08D	
							1.5 ... 15	DBC-08E	
215	393	128	P	12000	30	G1 $\frac{1}{2}$	0.2 ... 1.5	DBC-12A	
							0.3 ... 3.0	DBC-12B	
							0.8 ... 8.0	DBC-12D	
							1.5 ... 15	DBC-12E	
215	393	128	P	12000	30	G2	0.2 ... 1.5	DBC-16A	
							0.3 ... 3.0	DBC-16B	
							0.8 ... 8.0	DBC-16D	
							1.5 ... 15	DBC-16E	



Special options, add the appropriate letter			
NPT	connection thread	from G $\frac{1}{4}$ (02)	DBC-... N
FKM o-ring	PTFE-diaphragm		DBC-... V
EPDM o-ring	PTFE-diaphragm		DBC-... E
flange connection	see chapter for stainless steel devices / flanges		DBC-... F.

Accessories			
pressure gauges	Ø 50 mm, 0...*2 bar, G $\frac{1}{4}$	for G $\frac{1}{4}$	MA5002-...*2
pressure gauges	Ø 63 mm, 0...*2 bar, G $\frac{1}{4}$	from G $\frac{1}{2}$	MA6302-...*2
mounting bracket	made of steel	for G $\frac{1}{8}$ and G $\frac{1}{4}$ (A2)	BW30-02
mounting nut	made of aluminium	for G $\frac{1}{8}$ and G $\frac{1}{4}$ (A2)	M30x1,5A
mounting bracket	made of steel	for G $\frac{1}{4}$ (02) to G $\frac{3}{4}$ (A6)	BW00-44
		for G $\frac{3}{4}$ (06) and G1	BW00-42
		for G1 $\frac{1}{2}$ and G2	BW00-61
set of mount. brackets	made of steel		

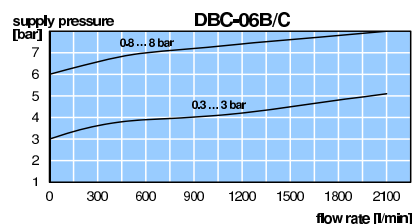
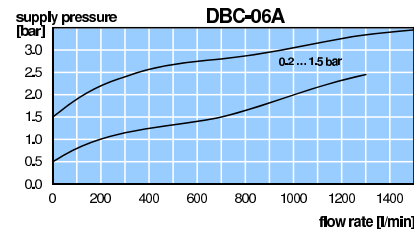
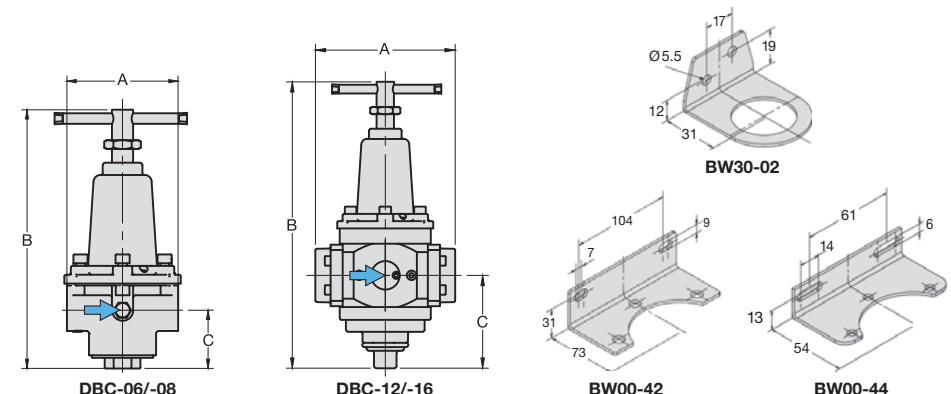

*1 at 7 bar overpressure and open outlet
 *2 02 = 0...2.5 bar, 04 = 0...4 bar, 06 = 0...6 bar, 10 = 0...10 bar, 16 = 0...16 bar
 *3 G $\frac{3}{4}$ thread at outlet

Description	Back pressure regulators protect pneumatic devices against overpressure. If the pressure exceeds the setpoint, the pressure valve exhausts to the atmosphere until the pressure level is below the setpoint. It is advisable to select the pressure range as near as possible to the maximum setpoint.		
Media	compressed air, non-corrosive gases or liquids		
Adjustment	by spindle with locknut for DBM-01	by black plastic knob with snap-lock for DBM-02	Overpressure see chart, max. 65 bar
Gauge port	G $\frac{1}{4}$ on both sides of the body, from DBC-02 on G $\frac{1}{8}$ at DBM-01, screw plugs supplied		
Temperature range	0 °C to 80 °C / 32 °F to 176 °F for FKM or EPDM 0 °C to 130 °C / 32 °F to 266 °F high temperature version, for appropriately conditioned compressed air down to -20 °C / -4 °F, or low temperature version down to -40 °C / -40 °F		
Mounting position	any		
Material	Body: brass	O-rings: FKM, optionally EPDM	Inner valve: brass
	Diaphragm: NBR/Buna-N with PTFE coating		

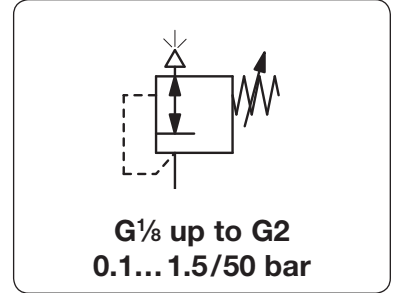

Dimensions			Regul. system	Relief	Over-	Connection	Adjustment	Order
A	B	C	D: diaphragm	capacity	pressure	thread	range	number
mm	mm	mm	P: piston	l/min*1	max. bar	G	bar	

Brass back pressure regulator					overpressure max. 30/50 bar		DBM	
40	82	10	D	400	30	G $\frac{1}{8}$	0.2 ... 1.5	DBM-01A
							0.3 ... 3.0	DBM-01B
							0.8 ... 8.0	DBM-01D
							1.5 ... 15	DBM-01E
40	82	10	D	400	30	G $\frac{1}{4}$	0.2 ... 1.5	DBM-A2A
							0.3 ... 3.0	DBM-A2B
							0.8 ... 8.0	DBM-A2D
							1.5 ... 15	DBM-A2E
63	140	34	D	800	30	G $\frac{1}{4}$	0.2 ... 1.5	DBM-02A
							0.3 ... 3.0	DBM-02B
							0.8 ... 8.0	DBM-02D
							1.5 ... 15	DBM-02E
63	141	34	P		65		3.0 ... 30	DBM-02F
63	156	34					5.0 ... 50	DBM-02G
63	140	34	D	800	30	G $\frac{3}{8}$	0.2 ... 1.5	DBM-03A
							0.3 ... 3.0	DBM-03B
							0.8 ... 8.0	DBM-03D
							1.5 ... 15	DBM-03E
63	141	34	P		65		3.0 ... 30	DBM-03F
63	156	34					5.0 ... 50	DBM-03G
78	161	38	D	2500	30	G $\frac{1}{2}$	0.2 ... 1.5	DBM-04A
							0.3 ... 3.0	DBM-04B
							0.8 ... 8.0	DBM-04D
							1.5 ... 15	DBM-04E
78	157	38	P		65		3.0 ... 30	DBM-04F
							5.0 ... 50	DBM-04G
118	289	66	D	8000	30	G $\frac{3}{4}$	0.2 ... 1.5	DBM-06A
							0.3 ... 3.0	DBM-06B
							0.8 ... 8.0	DBM-06D
							1.5 ... 15	DBM-06E
118	314	66	P		65		3.0 ... 30	DBM-06F
							5.0 ... 50	DBM-06G
118	289	66	D	8000	30	G1	0.2 ... 1.5	DBM-08A
							0.3 ... 3.0	DBM-08B
							0.8 ... 8.0	DBM-08D
							1.5 ... 15	DBM-08E
							3.0 ... 30	DBM-08F
							5.0 ... 50	DBM-08G



DBM-02/-03



DBM-04 accessories: gauge



DBM-06/-08

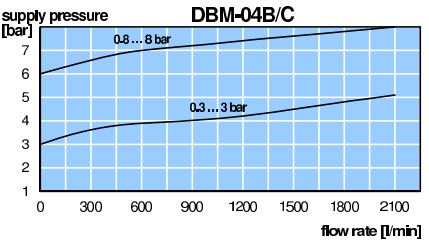
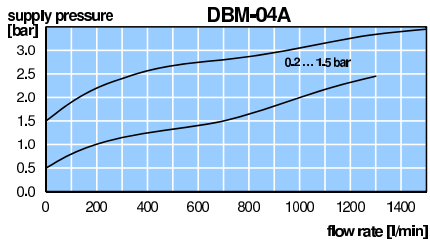
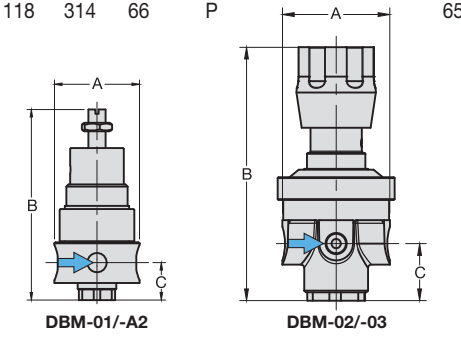
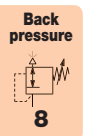

*1 at 7 bar overpressure and open outlet
*2 02 = 0...2.5 bar, 04 = 0...4 bar, 06 = 0...6 bar, 10 = 0...10 bar, 16 = 0...16 bar, 25 = 0...25 bar, 60 = 0...60 bar

Description	Back pressure regulators protect pneumatic devices against overpressure. If the pressure exceeds the setpoint, the pressure valve exhausts to the atmosphere until the pressure level is below the setpoint. It is advisable to select the pressure range as near as possible to the maximum setpoint.		
Media	compressed air, non-corrosive gases or liquids	Overpressure	see chart, max. 65 bar
Adjustment	by spindle with locknut for DBM-01 by T-handle with locknut for DBM-04/-08	by black plastic knob with snap-lock for DBM-02 by hexagonal spindle (spanner size 24 mm) with locknut for DBM-12/-16	
Gauge port	G $\frac{1}{4}$ on both sides of the body, from DBC-02 on	G $\frac{1}{2}$ at DBM-01, screw plugs supplied	
Temperature range	0 °C to 80 °C / 32 °F to 176 °F for FKM or EPDM 0 °C to 130 °C / 32 °F to 266 °F high temperature version, for appropriately conditioned compressed air down to -20 °C / -4 °F, or low temperature version down to -40 °C / -40 °F		
Mounting position	any		
Material	Body: brass Diaphragm: NBR/Buna-N with PTFE coating	O-rings: FKM, optionally EPDM Inner valve: brass	

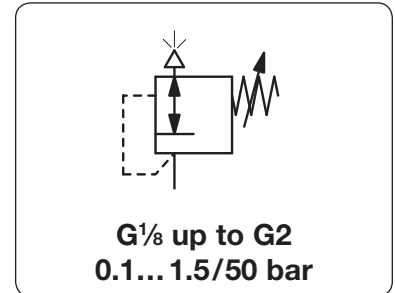

Dimensions			Regul. system	Relief capacity	Over-pressure	Connection thread	Adjustment range	Order number
A	B	C	D: diaphragm P: piston	l/min*1	max. bar	G	bar	

Brass back pressure regulator							overpressure max. 30/50 bar	DBM
180	385	128	D	25 000	30	G $\frac{1}{2}$	0.2... 1.5	DBM-12A
							0.3... 3.0	DBM-12B
							0.8... 8.0	DBM-12D
							1.5... 15	DBM-12E
180	400	128	P		65		3.0... 30	DBM-12F
							5.0... 50	DBM-12G
180	385	128	D	25 000	30	G2	0.2... 1.5	DBM-16A
							0.3... 3.0	DBM-16B
							0.8... 8.0	DBM-16D
							1.5... 15	DBM-16E
180	400	128	P		65		3.0... 30	DBM-16F
							5.0... 50	DBM-16G



DBM-12/-16

Special options, add the appropriate letter

NPT	connection thread	from G $\frac{1}{4}$ (02)	DBM-... N
down to -40 °C / -40 °F	low temperature version		DBM-... X51
up to 130 °C / 266 °F	high temperature version	up to DBM-04	DBM-0... X54
EPDM o-ring	PTFE diaphragm		DBM-... E
T-handle	instead of knob	DBM-02 only	DBM-02... T
flange connection	see chapter for stainless steel devices / flanges		DBM-... F
nitrogen	N $_2$: 07	carbon dioxide CO $_2$: 03	argon Ar: DBM-... 05
helium	He: 09	hydrogen H $_2$: 11	methane CH $_4$: DBM-... 13
oxygen	O $_2$: 15	propane C $_3$ H $_8$: 16	nitrous oxide N $_2$ O: DBM-... 17
		water H $_2$ O: 18	DBM-... W

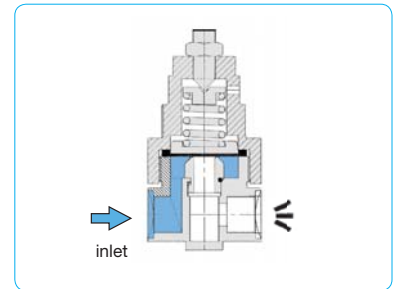

cross-section with diaphragm (D)

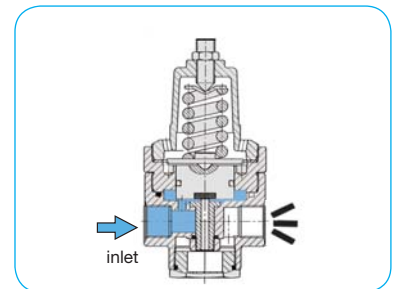

cross-section with piston (P)

Accessories

pressure gauge	Ø 50 mm, 0...*2 bar, G $\frac{1}{4}$ on the back	for G $\frac{1}{4}$ and G $\frac{1}{2}$	MA5002-...*2
pressure gauge	Ø 63 mm, 0...*2 bar, G $\frac{1}{4}$ on the back	for G $\frac{3}{4}$ to G2	MA6302-...*2
mounting bracket	made auf stainless steel	for G $\frac{1}{4}$ and G $\frac{3}{8}$	BW35-01S
mounting nut	made auf stainless steel	for G $\frac{1}{4}$ and G $\frac{3}{8}$	M35x1,5S
mounting bracket	made auf stainless steel	for G $\frac{1}{2}$	BW50-01S
mounting nut	made auf stainless steel	for G $\frac{1}{2}$	M50x1,5S
mounting bracket	made of steel	for G $\frac{3}{4}$ and G1	BW00-42
set of mount. brackets	made of steel	for G $\frac{1}{2}$ and G2	BW00-61

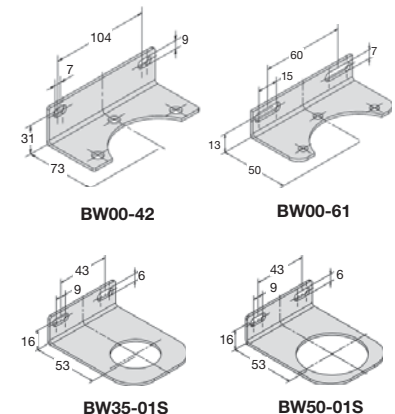
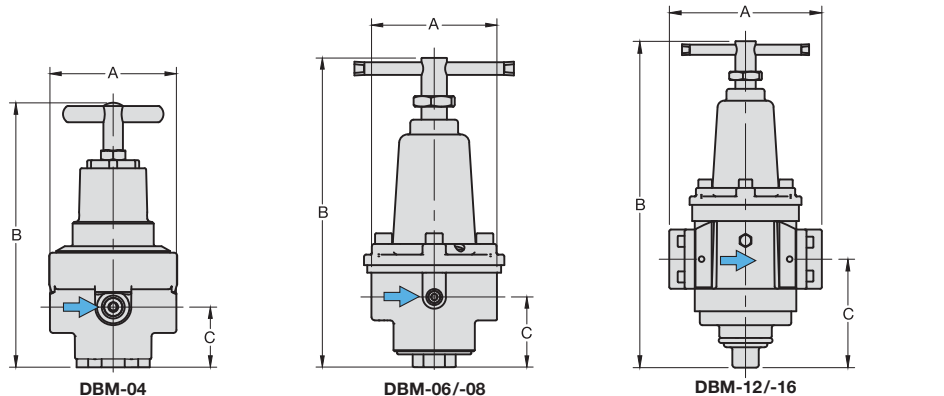

*1 at 7 bar overpressure and open outlet
*2 02 = 0...2.5 bar, 04 = 0...4 bar, 06 = 0...6 bar, 10 = 0...10 bar, 16 = 0...16 bar, 25 = 0...25 bar, 60 = 0...60 bar

Gauges: see chapter for measuring devices

PDF CAD
www.aircom.net

Order example:
DBM-12A

Precision Back Pressure Regulator of Advanced Accuracy, up to 35 bar

10BP

Description	The back pressure regulator is a high-flow, high-precision pneumatic relief valve with adjustable setpoint. It provides protection against overpressure in the downstream section of pneumatic systems. A convoluted diaphragm provides the sensitivity for venting to the atmosphere in response to the slightest upstream change.
Media	compressed air or non-corrosive gases
Overpressure	max. 21 bar up to pressure range of 14 bar, max. 35 bar beyond
Adjustment	by handwheel with locknut
Gauge port	G $\frac{1}{4}$ on both sides of the body, screw plugs supplied
Mounting position	any
Temperature range	0 °C to 90 °C / 32 °F to 194 °F, for appropriately conditioned compressed air down to -40 °C / -40 °F
Material	Body: aluminium die-cast Elastomer: NBR/Buna-N, optionally FKM Inner valve: stainless steel and brass

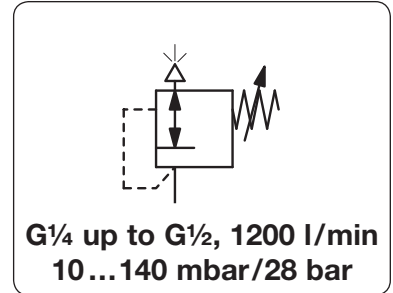

Dimensions			Relief capacity l/min*1	Over-pressure max. bar	Connection thread G	Adjustment range bar	Order number
A	B	C					

Precision back pressure regulator							overpressure max. 21/35 bar	Model 10BP
67	162	19	1200	21	G $\frac{1}{4}$	0.01 ... 0.14	10212BPH	
						0.01 ... 0.7	10222BPH	
						0.01 ... 2.1	10232BPH	
						0.07 ... 4.1	10242BPH	
						0.14 ... 10	10262BPH	
67	171	19	1200	35	G $\frac{1}{4}$	0.20 ... 14	10272BPH	
						0.30 ... 21	10282BPH	
						0.30 ... 28	10292BPH	



Special options, add the appropriate letter

G $\frac{3}{8}$	connection thread	102.3BPH
G $\frac{1}{2}$	connection thread, recommended for mbar range	102.4BPH
NPT	connection thread	102.2BP
FKM elastomer		102. .BP . J
free of non-ferrous metal	FKM elastomer	102. .BP . X63
tamper-proof cap	aluminium, adjustment by screwdriver, total height 159 mm	102. .BP . T

Accessories

pressure gauge	Ø 50 mm, 0...*2 bar, G $\frac{1}{4}$	MA5002-...*2
	Ø 63 mm, 0...160 mbar, G $\frac{1}{4}$	MA6302- C2
mounting bracket	made of steel	BW00-34

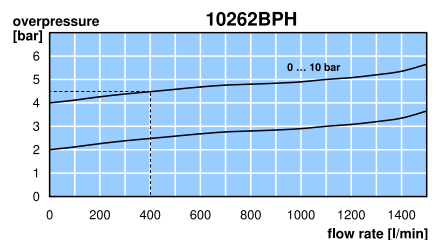
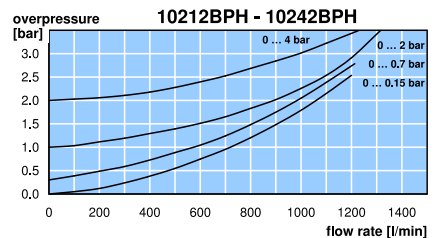
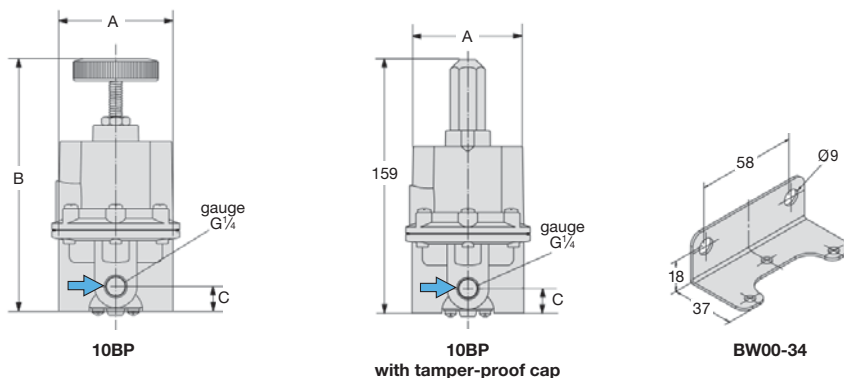
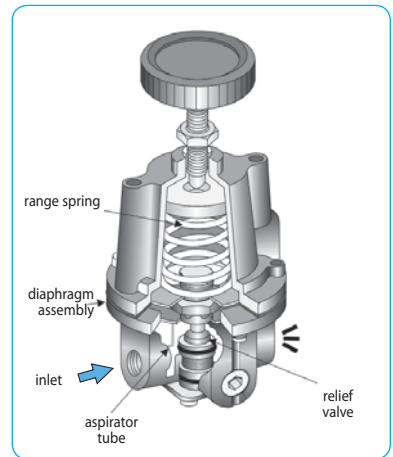

*1 at 5 bar overpressure and open outlet
*2 01 = 0...1 bar, 02 = 0...2.5 bar, 06 = 0...6 bar, 10 = 0...10 bar, 16 = 0...16 bar, 25 = 0...25 bar, 60 = 0...60 bar

Gauges: see chapter for measuring devices

PDF CAD
www.aircom.net

Order example:
10212BPH

Description	The back pressure regulator is a high-flow, high-precision pneumatic relief valve with adjustable setpoint. It provides protection against overpressure in the downstream section of pneumatic systems. A convoluted diaphragm provides the sensitivity for venting to the atmosphere in response to the slightest upstream change.
Media	compressed air or non-corrosive gases
Overpressure	max. 17 bar
Adjustment	by handwheel with locknut
Gauge port	G $\frac{1}{4}$ on both sides of the body, screw plugs supplied
Mounting position	any
Temperature range	0 °C to 70 °C / 32 °F to 158 °F, for appropriately conditioned compressed air down to -40 °C / -40 °F
Material	Body: aluminium die-cast Elastomer: NBR/Buna-N Inner valve: stainless steel and brass

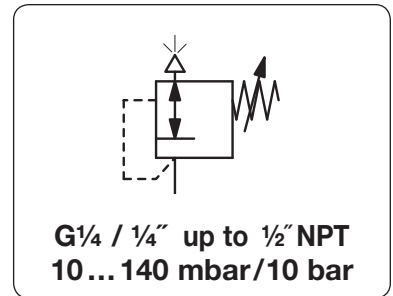

Dimensions			Relief capacity l/min*1	Over-pressure max. bar	Connection thread G	Adjustment range bar	Order number
A	B	C					

Precision back pressure regulator							overpressure max. 17 bar	DB240
67	154	19	1100	17	G $\frac{1}{4}$	0.01 ... 0.14	DB240-020	
						0.01 ... 1.0	DB240-02A	
						0.01 ... 2.0	DB240-02B	
						0.07 ... 4.0	DB240-02C	
						0.14 ... 10	DB240-02D	



DB240

Special options, add the appropriate letter

$\frac{1}{4}$" NPT	connection thread	DB240-02 . N
$\frac{3}{8}$" NPT	connection thread	DB240-03 . N
$\frac{1}{2}$" NPT	connection thread, recommended for mbar range	DB240-04 . N
tamper-proof cap	aluminium, adjustment by screwdriver, total height 157 mm	DB240-0 . . T

Accessories

pressure gauge	\varnothing 50 mm, 0...*2 bar, G $\frac{1}{4}$, Bourdon tube, from 1 bar on	MA5002-...*2
	\varnothing 63 mm, 0...160 mbar, G $\frac{1}{4}$, capsule type	MA6302- C2
mounting bracket	made of steel	BW00-33

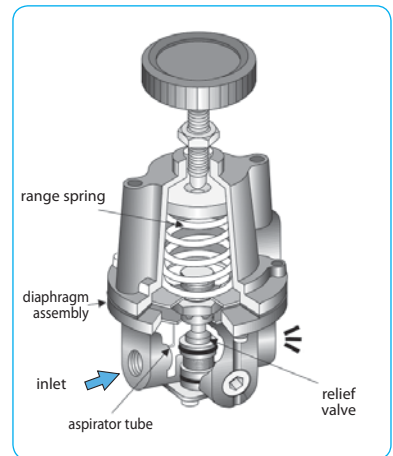

cross-section

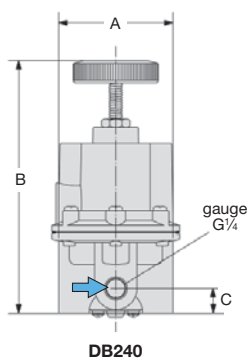
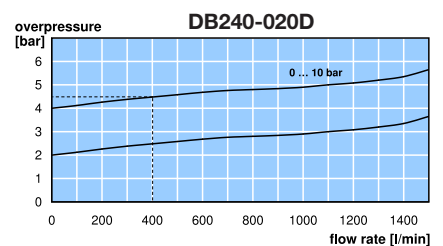
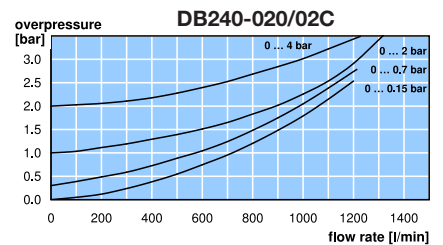

DB240

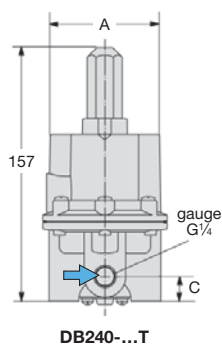

DB240-...T
with tamper-proof cap

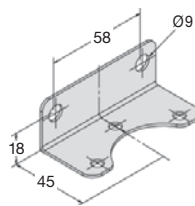

BW00-33

*1 at 5 bar overpressure and open outlet
*2 01 = 0...1 bar, 02 = 0...2.5 bar, 06 = 0...6 bar, 10 = 0...10 bar, 16 = 0...16 bar

Gauges: see chapter for measuring devices

PDF CAD
www.aircom.net

Order example:
DB240-020

Description Diaphragm back pressure regulators protect pneumatic devices against overpressure. If the pressure exceeds the setpoint, the pressure valve exhausts to the atmosphere until the pressure level is below the setpoint. It is advisable to select the pressure range as near as possible to the maximum setpoint.

Media compressed air or non-corrosive gases

Recommendation connection thread G½ for pressure range 0...35 / 140 / 280 mbar

Overpressure max. 10 bar

Accuracy response sensitivity <2 mbar

Adjustment by handwheel with locknut

Gauge port G¼ on both sides of the body, screw plugs supplied

Mounting position any

Temperature range 0 °C to 90 °C / 32 °F to 194 °F, for appropriately conditioned compressed air down to -40 °C / -40 °F

Material Body: aluminium die-cast
Elastomer: NBR/Buna-N, optionally FKM
Inner valve: stainless steel and brass

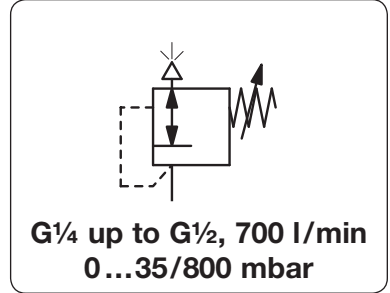

Dimensions			Relief capacity l/min*1	Over-pressure max. bar	Connection thread G	Adjustment range mbar	Order number
A	B	C					

Low back pressure regulator							overpressure max. 10 bar	DB110
67	180	25	700	10	G¼	2... 35	DB110-020	
						2... 140	DB110-02A	
						2... 280	DB110-02B	
						2... 400	DB110-02C	
						2... 800	DB110-02D	
67	180	25	700	10	G½	2... 35	DB110-040	
						2... 140	DB110-04A	
						2... 280	DB110-04B	
						2... 400	DB110-04C	
						2... 800	DB110-04D	



DB110

Special options, add the appropriate letter

G¾	connection thread	DB110-0.. 3
NPT	connection thread	DB110-0.. N
FKM elastomer		DB110-0.. V
tamper-proof cap	aluminium, adjustment by screwdriver, total height 183 mm	DB110-0.. T

Accessories

pressure gauge	Ø 63 mm, 0...*2 mbar, G¼, capsule type	MA6302-...*2
	Ø 63 mm, 0... 1 bar, G¼, Bourdon tube	MA6302-01
connecting parts gauge	at NPT connection thread, adapter ¼" NPT - G¼i	VP-0202N
mounting bracket	made of steel	BW00-58

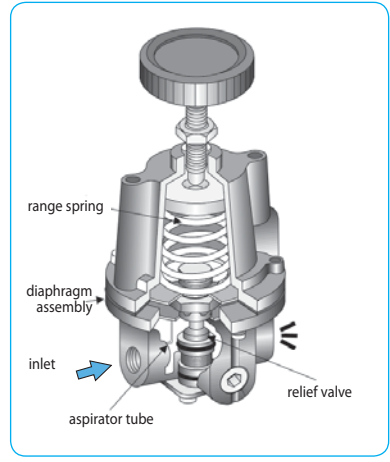

Back pressure
8

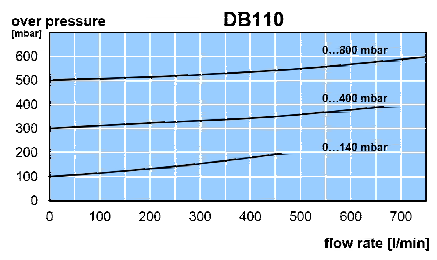
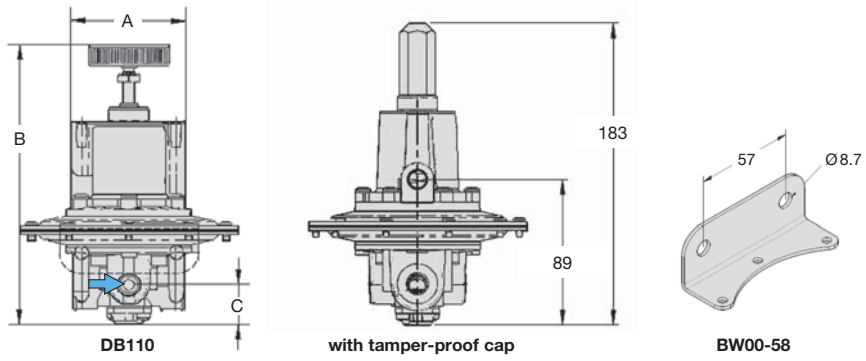

*1 at 200 mbar overpressure and open outlet
*2 B6 = 0...60 mbar, C2 = 0...160 mbar, C3 = 0...250 mbar, C4 = 0...400 mbar

Gauges: see chapter for measuring devices

PDF CAD
www.aircom.net

Order example:
DB110-020

Precision Back Pressure Regulator, small and lightweight

DB300

Description	Diaphragm back pressure regulators protect pneumatic devices against overpressure. If the pressure exceeds the setpoint, the pressure valve exhausts to the atmosphere until the pressure level is below the setpoint. It is advisable to select the pressure range as near as possible to the maximum setpoint.
Media	compressed air or non-corrosive gases
Overpressure	max. 10 bar
Accuracy	response sensitivity <2 mbar
Adjustment	by handwheel with locknut
Gauge port	G $\frac{1}{8}$ on both sides of the body, screw plugs supplied
Mounting position	any
Temperature range	0 °C to 90 °C / 32 °F to 194 °F, for appropriately conditioned compressed air down to -40 °C / -40 °F
Material	Body: aluminium die-cast Elastomer: NBR/Buna-N, optionally FKM Inner valve: brass

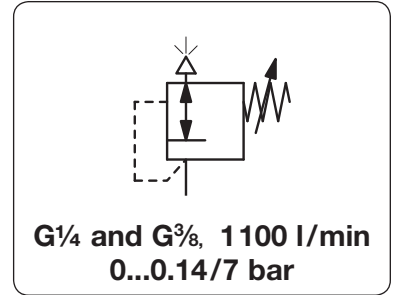

Dimensions			Relief capacity l/min*1	Over-pressure max. bar	Connection thread G	Adjustment range mbar	Order number
A	B	C					

Precision back pressure regulator							overpressure max. 10 bar	DB300
57	126	19	1100	10	G $\frac{1}{4}$	0.001... 0.14	DB300-020	
						0.01 ... 0.7	DB300-021	
						0.03 ... 2.0	DB300-02A	
						0.07 ... 4.0	DB300-02B	
						0.14 ... 7.0	DB300-02C	
57	126	19	1100	10	G $\frac{3}{8}$	0.001... 0.14	DB300-030	
						0.01 ... 0.7	DB300-031	
						0.03 ... 2.0	DB300-03A	
						0.07 ... 4.0	DB300-03B	
						0.14 ... 7.0	DB300-03C	



DB300

Special options, add the appropriate letter

NPT	connection thread	DB300-0..N
tamper-proof cap	aluminium, adjustment by screwdriver, total height 141 mm	DB300-0..T
FKM elastomer		DB300-0..V

Accessories

pressure gauge	Ø 63 mm, 0... 160 mbar, G $\frac{1}{4}$ -connecting parts required	MA6302-C2
	Ø 50 mm, 0...*2 bar, G $\frac{1}{8}$	MA5001-..*2
connecting parts gauge	for MA6302-C2	AM-04
mounting bracket	made of steel	BW00-46

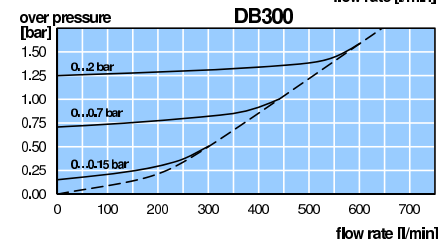
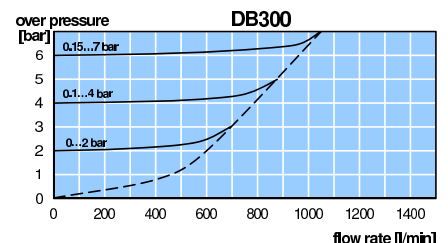
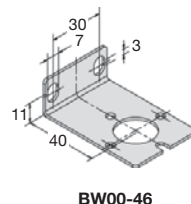
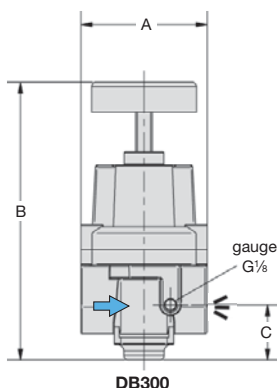
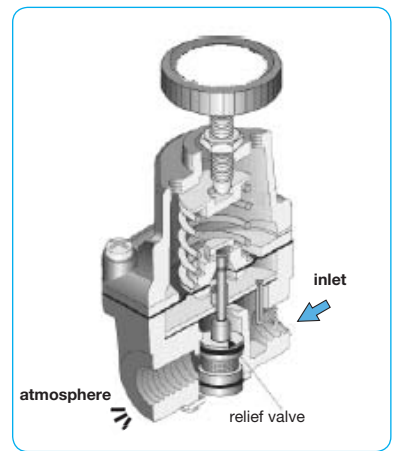

*1 at 7 bar overpressure and open outlet
*2 01 = 0...1 bar, 02 = 0...2.5 bar, 04 = 0...4 bar, 10 = 0...10 bar

Gauges: see chapter for measuring devices

PDF CAD
www.aircom.net

Order example:
DB300-020

Description	Diaphragm back pressure regulators protect pneumatic devices against overpressure. If the pressure exceeds the setpoint, the pressure valve exhausts to the atmosphere until the pressure level is below the setpoint. It is advisable to select the pressure range as near as possible to the maximum setpoint.
Media	compressed air or non-corrosive gases
Overpressure	max. 17 bar
Adjustment	by handwheel with locknut
Gauge port	G $\frac{1}{4}$ on both sides of the body, screw plugs supplied
Mounting position	any
Temperature range	0 °C to 90 °C / 32 °F to 194 °F, for appropriately conditioned compressed air down to -40 °C / -40 °F
Material	Body: aluminium die-cast Elastomer: NBR/Buna-N, optionally FKM Inner valve: stainless steel, brass, aluminium and cadmium-plated steel

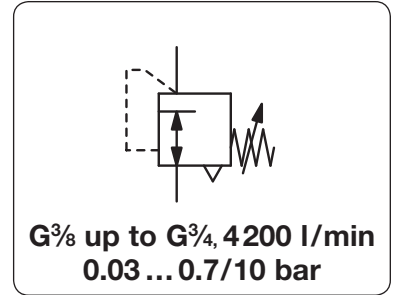

Dimensions			Relief capacity l/min*1	Over-pressure max. bar	Connection thread G	Adjustment range mbar	Order number
A	B	C					

Precision back pressure regulator							overpressure max. 17 bar	DB400
89	206	39	3800	17	G $\frac{3}{8}$	0.03 ... 0.7		DB400-031
						0.03 ... 2.0		DB400-03A
						0.07 ... 4.0		DB400-03B
						0.15 ... 10		DB400-03C
89	206	39	4000	17	G $\frac{1}{2}$	0.03 ... 0.7		DB400-041
						0.03 ... 2.0		DB400-04A
						0.07 ... 4.0		DB400-04B
						0.15 ... 10		DB400-04C
89	206	39	4200	17	G $\frac{3}{4}$	0.03 ... 0.7		DB400-061
						0.03 ... 2.0		DB400-06A
						0.07 ... 4.0		DB400-06B
						0.15 ... 10		DB400-06C



DB400

Special options, add the appropriate letter

NPT	connection thread	DB400-0..N
tamper-proof cap	aluminium, adjustment by screwdriver, total height 295 mm	DB400-0..T
FKM elastomer		DB400-0..V

Accessories

pressure gauge	Ø 63 mm, 0...*2 bar, G $\frac{1}{4}$	MA6302-...*2
mounting bracket	made of steel	BW00-47

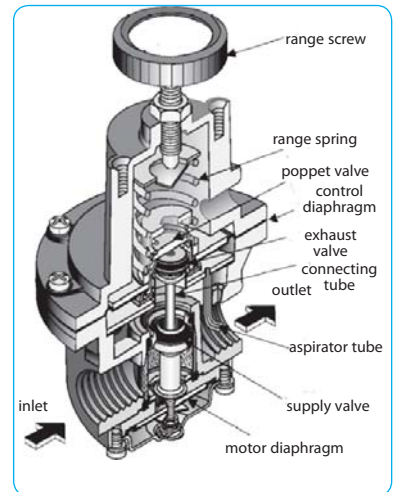

cross-section

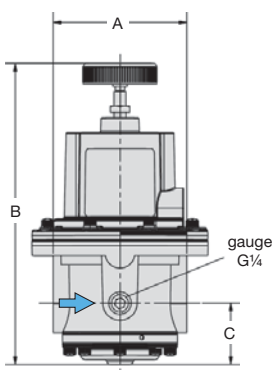

DB400

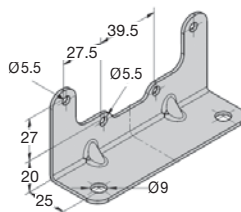

BW00-47

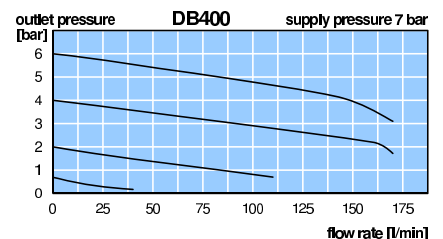

*1 at 7 bar inlet pressure and 1.4 bar outlet pressure
*2 01 = 0...1 bar, 02 = 0...2.5 bar, 04 = 0...4 bar, 10 = 0...10 bar, 25 = 0...25 bar

Gauges: see chapter for measuring devices

PDF CAD
www.aircom.net

Order example:
DB400-031

Description	Diaphragm back pressure regulators protect pneumatic devices against overpressure. If the pressure exceeds the setpoint, the pressure valve exhausts to the atmosphere until the pressure level is below the setpoint. It is advisable to select the pressure range as near as possible to the maximum setpoint.
Media	compressed air or non-corrosive gases
Overpressure	max. 6 bar
Adjustment	by handwheel with locknut for DBC-04 by hexagonal spindle (spanner size 24 mm) with locknut for DBC-08/-16
Gauge port	G $\frac{1}{4}$ for operation pressure, on both sides of the body, connection parts required
Mounting position	any
Temperature range	-20 °C to 60 °C / -4 °F to 140 °F
Material	Body: aluminium Diaphragm: NBR/Buna-N with PTFE coating O-rings: NBR/Buna-N, optionally FKM or EPDM Inner valve: brass

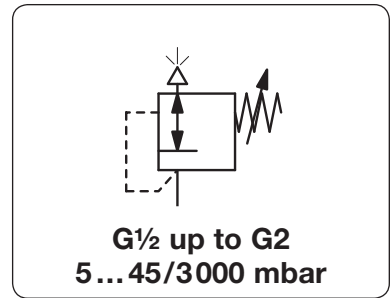

Dimensions			Relief capacity l/min*1	Over-pressure max. bar	Connection thread G	Adjustment range mbar	Order number
A	B	C					

Aluminium back pressure regulator			NBR/Buna-N with PTFE coating		DBC		
82	191	38	300	6	G $\frac{1}{2}$	5 ... 45	DBC-04N
			500			20 ... 200	DBC-04P
			1000			150 ... 700	DBC-04Q
161	299	45	1300	6	G $\frac{3}{4}$	50 ... 300	DBC-06P
			2300			100 ... 700	DBC-06Q
			5000			200 ... 1200	DBC-06R
161	299	45	1300	6	G1	50 ... 300	DBC-08P
			2300			100 ... 700	DBC-08Q
			5000			200 ... 1200	DBC-08R
265	299	45	1300	6	G1 $\frac{1}{4}$	50 ... 300	DBC-10P
			2300			100 ... 700	DBC-10Q
			5000			200 ... 1200	DBC-10R
265	299	45	1300	6	G1 $\frac{1}{2}$	50 ... 300	DBC-1AP
			2300			100 ... 700	DBC-1AQ
			5000			200 ... 1200	DBC-1AR
215	444	128	2500	6	G1 $\frac{1}{2}$	20 ... 50	DBC-12N
			5000			50 ... 150	DBC-12P
			7500			150 ... 300	DBC-12Q
			10000			300 ... 3000	DBC-12R
215	444	128	2500	6	G2	20 ... 50	DBC-16N
			5000			50 ... 150	DBC-16P
			7500			150 ... 300	DBC-16Q
			10000			300 ... 3000	DBC-16R



DBC-04



DBC-06/-08



DBC-12/-16

Special options, add the appropriate letter

NPT	connection thread	for G $\frac{1}{2}$, G1 $\frac{1}{2}$ (12) and G2	DBC-... N
NPT	connection thread	for G $\frac{3}{4}$ to G1 $\frac{1}{2}$ (1A)	DBC-... N
FKM o-ring	PTFE-diaphragm		DBC-... V
EPDM o-ring	PTFE-diaphragm		DBC-... E
flange connection	see chapter for stainless steel devices / flanges		DBC-... F.

Accessories

pressure gauge	Ø 63 mm, 0...*2 mbar, G $\frac{1}{4}$, capsule type, up to 400 mbar	MA6302-...*2
	Ø 63 mm, 0...*2 bar, G $\frac{1}{4}$, Bourdon tube, up 1 bar	MA6302-...*2
connection parts	required for pressure gauge	AM-01
mounting bracket	made of stainless steel	BW00-26S

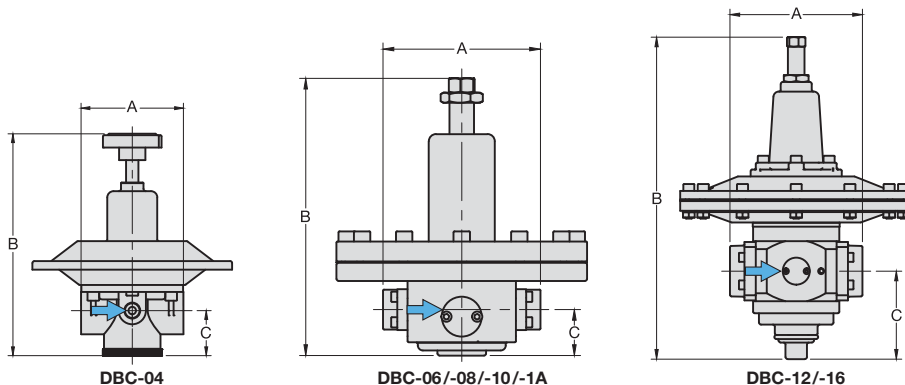

*1 at 6 bar overpressure and open outlet
*2 B6 = 0...60 mbar, C2 = 0...160 mbar, C4 = 0...400 mbar, C01 = 0...1 bar, 04 = 0...4 bar, 06 = 0...6 bar

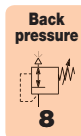

Description	Diaphragm back pressure regulators protect pneumatic devices against overpressure. If the pressure exceeds the setpoint, the pressure valve exhausts to the atmosphere until the pressure level is below the setpoint. It is advisable to select the pressure range as near as possible to the maximum setpoint.		
Media	compressed air or non-corrosive gases		
Overpressure	max. 17 bar	Pilot pressure	0 ... 10 bar
Accuracy	1% at 7 bar pilot pressure	Response sensitivity	1 mbar
Adjustment	depending on the level of signal pressure the response value will change accordingly		
Gauge port	G $\frac{1}{4}$ on both sides of the body, screw plugs supplied	Mounting position	any
Temperature range	0 °C to 90 °C / 32 °F to 194 °F, for appropriately conditioned compressed air down to -40 °C / -40 °F		
Material	Body: aluminium die casting O-rings: NBR/Buna-N, optionally FKM	Elastomer:	NBR/Buna-N Inner valve: brass and zinc-plated steel

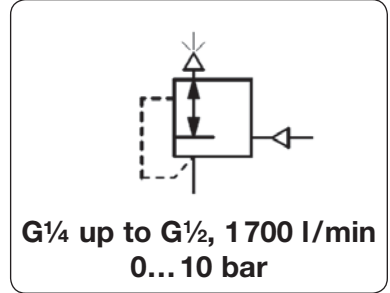

Dimensions			Relief capacity l/min*1	Over-pressure max. bar	Adjustment range bar	Connection thread G	Order number
A	B	C					

Back pressure regulator, pilot-operated							pilot pressure overpressure	0...10 bar max. 17 bar	DB208
76	98	24	1700	17	0... 10	G $\frac{1}{4}$		DB208-02	
						G $\frac{3}{8}$		DB208-03	
						G $\frac{1}{2}$		DB208-04	



DB208

Special options, add the appropriate letter

NPT	connection thread	DB208-0.N
FKM elastomer		DB208-0.V

Accessories

pressure gauge	Ø 50 mm, 0...*2 bar, G $\frac{1}{4}$	MA5002-...*2
mounting bracket	made of steel	BW00-34

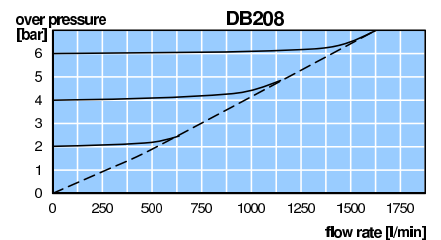
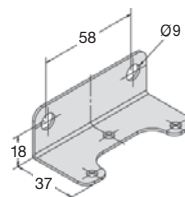
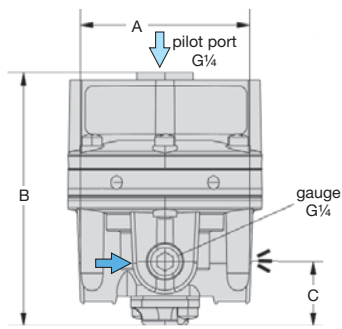
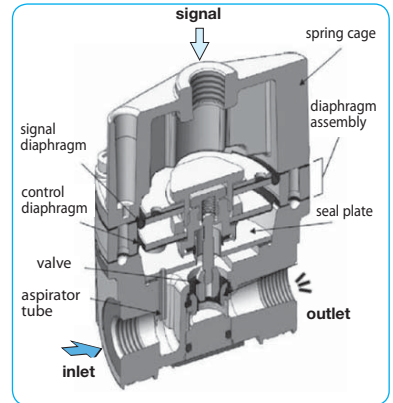

*1 at 7 bar inlet pressure and open outlet
*2 02 = 0...2.5 bar, 04 = 0...4 bar, 06 = 0...6 bar, 10 = 0...10 bar

Gauges: see chapter for measuring devices

PDF CAD
www.aircom.net



Order example:
DB208-02

Description	Diaphragm back pressure regulators protect pneumatic devices against overpressure. If the pressure exceeds the setpoint, the pressure valve exhausts to the atmosphere until the pressure level is below the setpoint. It is advisable to select the pressure range as near as possible to the maximum setpoint.		
Media	compressed air or non-corrosive gases		
Overpressure	max. 17 bar	Pilot pressure	0 ... 10 bar
Accuracy	3% at 7 bar pilot pressure	Response sensitivity	2.5 mbar
Adjustment	depending on the level of signal pressure the response value will change accordingly		
Gauge port	G $\frac{1}{4}$ on both sides of the body, screw plugs supplied	Mounting position	any
Temperature range	0 °C to 90 °C / 32 °F to 194 °F, for appropriately conditioned compressed air down to -40 °C / -40 °F		
Material	Body: aluminium die casting O-rings: NBR/Buna-N, optionally FKM	Elastomer:	NBR/Buna-N
		Inner valve:	brass and aluminium

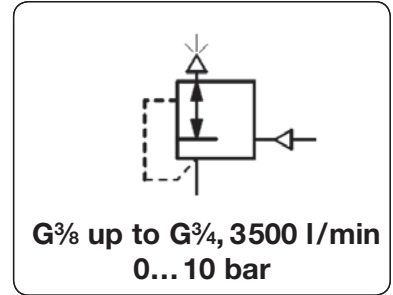

Dimensions			Relief capacity	Over-pressure	Adjustment range	Connection thread	Order number
A	B	C	l/min*1	max. bar	bar	G	
mm	mm	mm					

Back pressure regulator, pilot-operated						pilot pressure overpressure	0...10 bar max. 17 bar	DB450
87	129	40	3500	17	0... 10	G $\frac{3}{8}$		DB450-03
						G $\frac{1}{2}$		DB450-04
						G $\frac{3}{4}$		DB450-06



DB450

Special options, add the appropriate letter		
NPT	connection thread	DB450-0. N
FKM elastomer		DB450-0. V

Zubehör, lose beigelegt		
pressure gauge	Ø 63 mm, 0...*2 bar, G $\frac{1}{4}$	MA6302-..*2
mounting bracket	made of steel	BW00-47

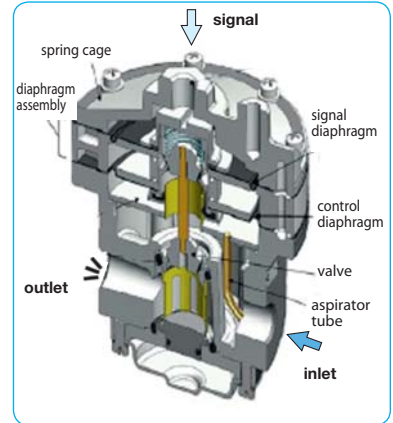

cross-section

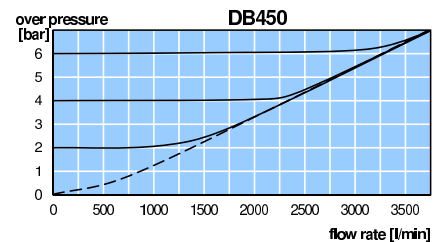
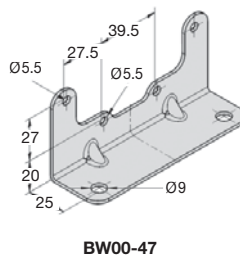
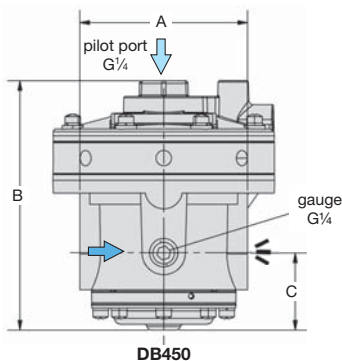

*1 at 6 bar inlet pressure and open outlet *2 02 = 0...2.5 bar, 04 = 0...4 bar, 06 = 0...6 bar, 10 = 0...10 bar

Miniature Back Pressure Regulator

Model 59/130/134

Description

Pressure relief valve for protecting compressed air devices from overpressure. If the pressure setpoint is exceeded, overpressure is vented into the atmosphere until the setpoint is reached again. It is recommended to choose a pressure range as low as possible.

Model 59 Model 130 / 134

Low-cost piston-operated valve of small size and high relief capacity. Small, sensitive diaphragm-type valve made to screw in. Relief flow is proportional to overpressure. Model 134 features a tapped exhaust.

Media Overpressure Adjustment

compressed air or non-corrosive gases, model 134 also for liquids
max. 21 bar

Gauge port

by knurled screw at model 59
by plastic knob with snap-lock at model 130 and 134

Temperature range Material

0 °C to 50 °C / 32 °F to 132 °F
Body: aluminium at model 59 and 130, brass at model 134
Elastomer: NBR/Buna-N at model 130 and 134
Spring cage: plastic at type 130 and 134
Seal: silicone at model 59
Inner valve: brass

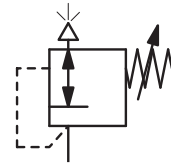

G $\frac{1}{4}$

Dimensions			relief capacity	Over-pressure	Connection thread	Adjustment range	Order number
A	B	C	l/min*1	max. bar	G	bar	
mm	mm	mm					

Back pressure regulator				overpressure max. 21 bar, with male thread	Model 59		
20	50	-	1500	21	G $\frac{1}{4}$ a	1.7... 2.4	59-02A- 35
						2.8... 3.5	59-02A- 50
						3.8... 14	59-02A-200

Back pressure regulator				overpressure max. 21 bar, with male thread	Model 130		
43	88	-	540	21	G $\frac{1}{4}$ a	0...3.5	130-02- 50
						0...7.0	130-02-100

Back pressure regulator				overpressure max. 21 bar with tapped exhaust and gauge port	Model 134		
40	76	10	540	21	G $\frac{1}{4}$	0...1.0	134-02- 15
						0...1.8	134-02- 25
						0...3.5	134-02- 50
						0...7.0	134-02-100

Special options, add the appropriate letter

free of grease and oil specially cleaned, suitable for oxygen for 130 and 134 13.-02-... L

Zubehör, lose beigelegt

pressure gauge	Ø 40 mm, 0...*2 bar, G $\frac{1}{8}$	for 134	MA4001-...*2
mounting bracket	made of steel	for 130 and 134	BW30-02
mounting nut	made of plastic	for 130 and 134	M30x1,5K
	made of aluminium	for 130 and 134	M30x1,5A

Model 59			relief		
range	set pressure	capacity	bar	Druck	l / min
3.8... 14	1.8 bar	500			
	3.6 bar	900			
	5.4 bar	1 100			
	7.0 bar	1 500			
	8.6 bar	1 700			
	10.0 bar	2 000			

Model 130			relief		
range	set pressure	capacity	bar	Druck	l / min
0...3.5	0.7 bar	50			
	1.8 bar	190			
	3.6 bar	310			
0...7	3.6 bar	280			
	5.2 bar	385			
	7.0 bar	540			

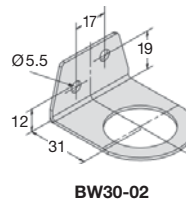

BW30-02



Model 59



Model 130



Model 134

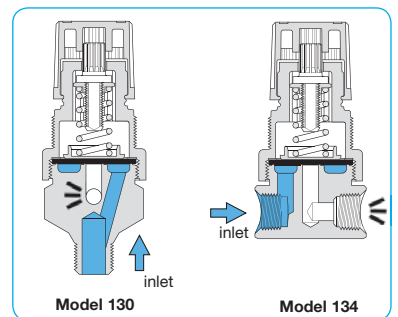

cross-section

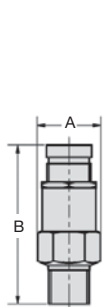

Model 59

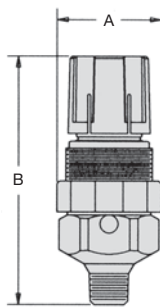

Model 130

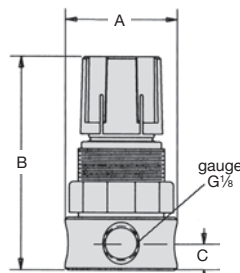

Model 134

*1 at 7 bar overpressure and open outlet

*2 01 = 0...1 bar, 02 = 0...2.5 bar, 04 = 0...4 bar, 10 = 0...10 bar

Gauges: see chapter for measuring devices

PDF CAD
www.aircom.net



Order example:
59-02A-35